

DAPR

Motorised Kit Speed Controller Guide



Index

Speed Controller Range.....3

Motorised Kit Wiring Guide.....4

Servo Controller Guide.....5

Mechanical Arm Wiring Diagram.....6

Info and Tips.....7

Electric Motor

Voltage - DC 1.5v – 6v

Speed – 3v/60RPM 6v/120RPM

Current – 0.02A

Notes – Comes with every motorised kit, pre wired and soldered, also available to purchase separately.



Option 1 – Speed Controller Only

Power – 1.8V – 6V

Current – 2A

Controller – Speed Controller

Notes – Controller comes preinstalled in a mountable casing with lid and connector block access, best suited for battery power supply.



Option 2 – Speed Controller & 3V Battery Holder

Power – 3V Battery Holder (2 x AA)

Controller – 1.8V - 6V Speed Controller

Notes – Controller comes preinstalled in a mountable casing with lid and connector block access.



Option 3 – Speed Controller & 6V Battery Holder

Power – 6V Battery Holder (4 x AA)

Controller – 1.8V – 6V Speed Controller

Notes – Controller comes preinstalled in a mountable casing with lid and connector block access.



Option 4 – Speed Controller with Forward/Reverse Control

Power – 6V - 24V

Controller – Speed Controller with Directional Control

Notes – Controller comes preinstalled in a mountable casing with direction control switch, also with lid and connector block access. Suited for kits where forward and reverse is required. *Please note, running at full speed may damage the motor, however this is an unlikely scenario as the motor speed at 50% is more than fast enough for a realistic scale speed for any motorised kit we offer.*



Option 5 – Speed Controller with Forward/Reverse Control & 6V Battery Holder

Power – 6V Battery Holder (4 x AA)

Controller – Speed Controller with Directional Control

Notes – Controller comes preinstalled in a mountable casing with direction control switch, also with lid and connector block access. Suited for kits where forward and reverse is best suited.



Motorised Kit Wiring Guide

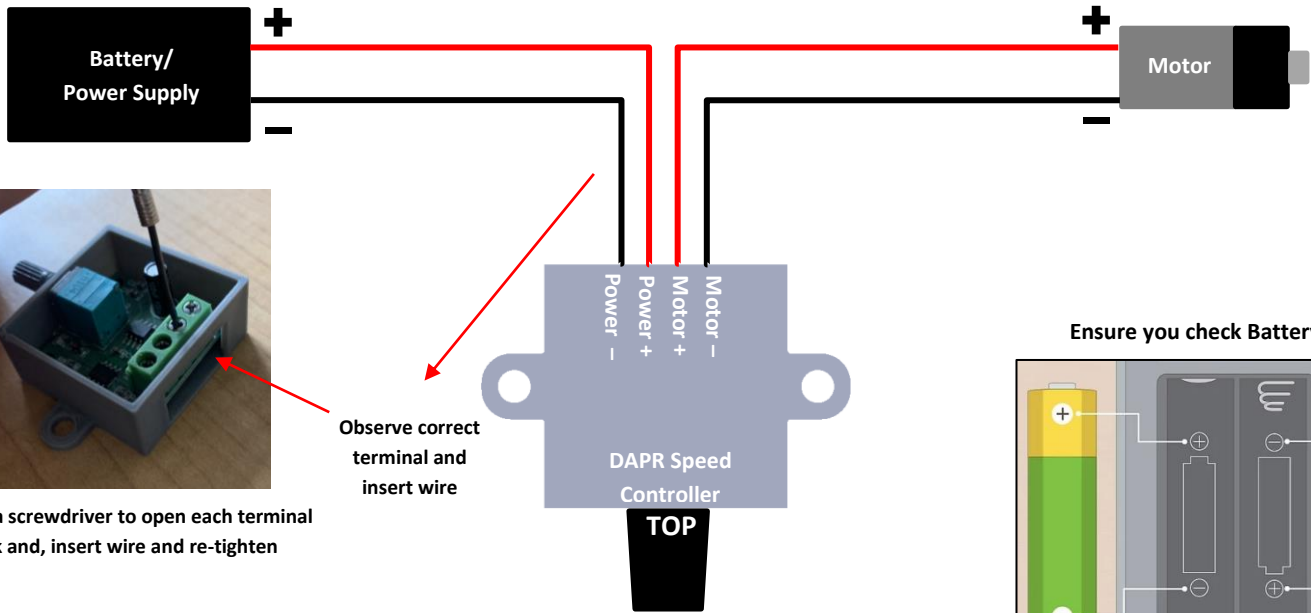

Controller Combination Options

Model	N		OO	
	Controller	Voltage	Controller	Voltage
Avalanche	Both	3-6v		
Chair O Plane	Standard	3-6v	Standard	3-6v
Divebombers	Direction Control	3-6v	Direction Control	6v-12v
Excavator	Direction Control	3-6v		
Ghost Train	Standard	3-6v	Standard	3-6v
Hook A Duck			Standard	3-6v
Inverted Ship	Direction Control	3-6v		
Jet Ride	Standard	3-6v	Standard	3-6v
Jet Ride V2	Standard	3-6v		
Mobile Crane	Direction Control	3-6v		
Mobile Jets	Standard	3-6v	Standard	3-6v
Paratroopers	Standard	3-6v	Standard	3-6v
Shooting Gallery			Standard	3-6v
Spinball	Direction Control	3-6v	Direction Control	3-6v
Tower Crane	Direction Control	3-6v		
Twister	Direction Control	3-6v		
Vintage Crane	Direction Control	3-6v		
Waltzer	Direction Control	3-6v	Direction Control	6v-12v
Water Mill	Standard	3-6v		
Wind Turbine	Standard	3-6v		
Windmill	Standard	3-6v		

Servo Controller

Servo Controller with 6V Battery Holder

Power – 4.5-6V Battery Holder (4 x AA)

Controller – **Servo Controller with 3 Modes**

Notes – Controller comes preinstalled in a mountable casing, the button next to the servo dial toggles between 3 servo modes.



Mode 1 - Manual

Turning the knob will move the servo

Mode 2 - Neutral

This mode will centre the servo

Mode 3 - 'Wiper'

This mode will automatically swing the servo backwards and forwards similar to windscreen wipers

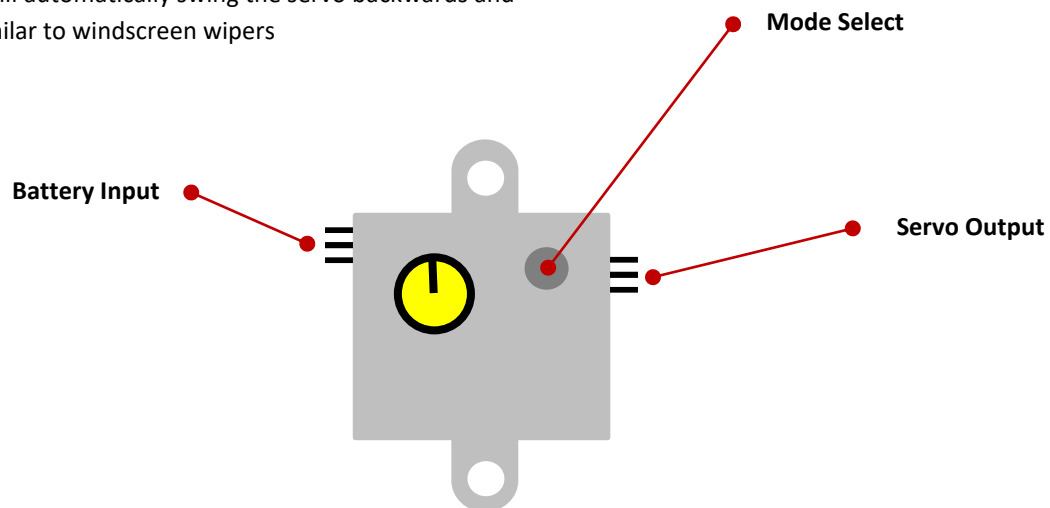

Mechanical Arm Wiring Diagram

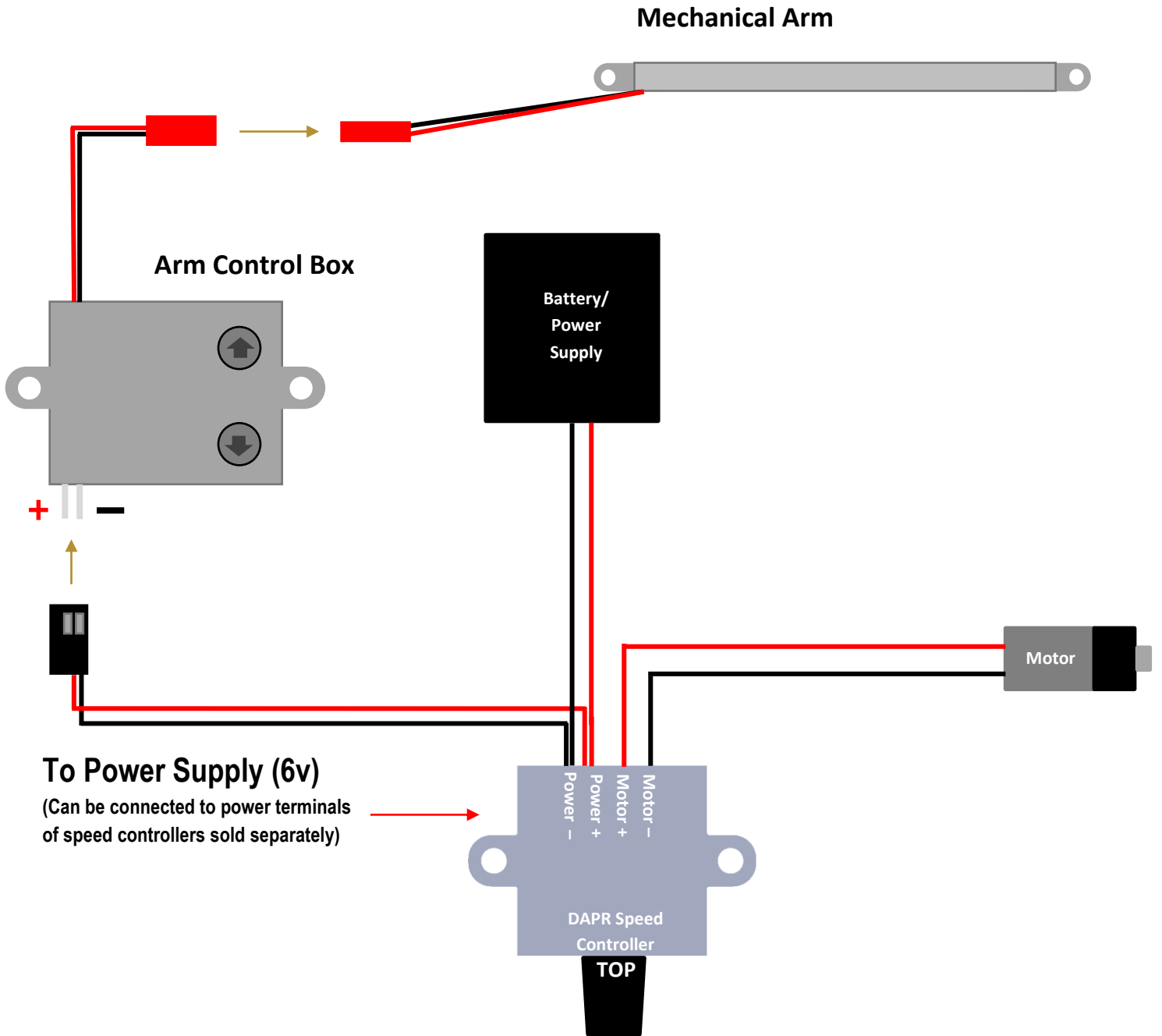

Further Info and Tips

- Please carefully observe battery polarity when installing.
- Do not leave running motorised kits unattended and ensure power is off when not in use.
- To connect to a 12v supply you will need the directional control version.
- Use the diagram on the previous page to assist wiring the unit, please double check all connections.
- Controller case colours and knob style may vary.
- The information in the table above is only a recommendation, different controller combinations may better suit your requirements.
- For further help and support please contact dapr3d@gmail.com
- Ensure all electrical components are correctly connected and insulated to avoid short circuits. Do not exceed the voltage specifications to prevent damage or injury. Always refer to this guide when installing.
- **If in double, get in touch!**

